

Dynapac CC1200

Double drum vibratory rollers

Atlas Copco



Technical data

Masses	
Max. operating mass	6,000 lbs
Operating mass (incl. ROPS)	5,700 lbs
Module mass (front/rear)	2,800 lbs/2,900 lbs

Propulsion	
Speed range	0-6 mph
Vertical oscillation	±10°
Theor. gradeability	43 %

Compaction	
Centrifugal force	7,420/8,170 lb
Nominal amplitude	0.020 in
Static linear load (front/rear)	59 /63 lbs/in
Vibration frequency	3,780/3,960 vpm
Water tank	42 gal

Engine	
Manufacturer/Model	Kubota D1703-M (T4i)
Type	Water cooled
Rated power, SAE J1995	35 hp @ 2,800 rpm
Fuel tank capacity	13 gal

Hydraulic system	
Driving	Axial piston pump with variable displacement. Radial piston motors (2) with constant displacement.
Vibration	Gear pump/motors with constant displacement.
Steering	Gear pump with constant displacement.
Service brake	Hydrostatic in forward and reverse lever.
Parking/Emergency brake	Failsafe multidisc brake in both drums.

Find us locally at www.atlascopco.com

We reserve the right to change specifications without notice. Photos and illustrations do not always show standard versions of machines. The above information is a general description only, all informations are supplied without liability.

rce_cc1200_us-20160418.111428.pdf 2016-04-18 11:14

Dynapac CC1200

Double drum vibratory rollers

Atlas Copco

Technical data

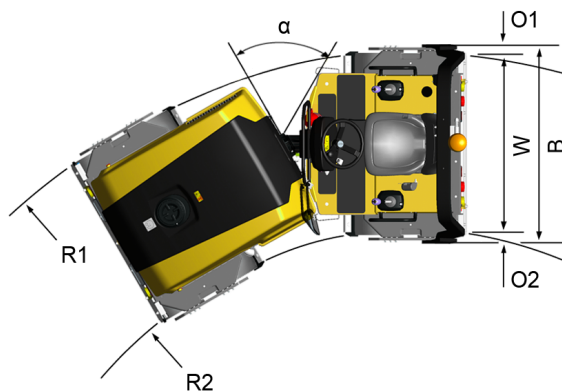
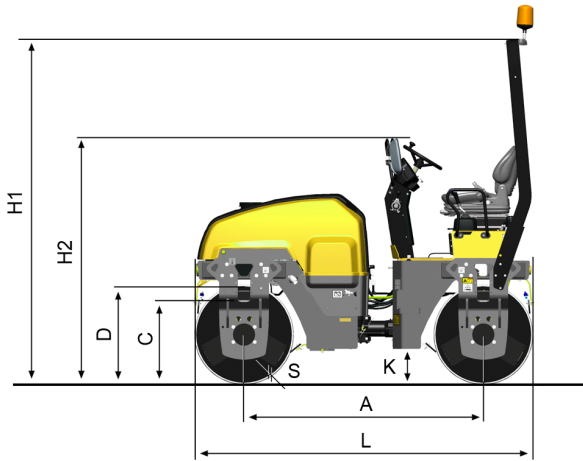

Dimensions	
A. Wheelbase	68 in
B. Width	52 in
C. Curb clearance	22 in
D. Drum diameter	27 in
H1. Height, with ROPS/cab	104 in
H2. Height, w/o ROPS/cab	69 in
K. Ground clearance	7 in
L. Length	94 in
O1. Overhang, right	2 in
O2. Overhang, left	2 in
R1. Turning radius, outside	150 in
R2. Turning radius, inside	102 in
S. Drum shell thickness	0.5 in
W. Drum width	47 in
α . Steering angle	$\pm 30^\circ$



Standard equipment

Backup alarm, Foldable ROPS incl. 3" seatbelt, Working lights



Optional equipment

Biodegradable hydraulic fluid, Fire extinguisher, Foot rest, Hearing protectors, Licence plate light, Rear view mirror (traffic view), Service kit 50/500/1000H, Side direction lights (driving lights required), Slow moving vehicle sign, Special color (one or two), Tool set, Towing eyelet, Water tank cover (lockable)

Find us locally at www.atlascopco.com

We reserve the right to change specifications without notice. Photos and illustrations do not always show standard versions of machines. The above information is a general description only, all informations are supplied without liability.

rce_cc1200_us-20160418.111428.pdf 2016-04-18 11:14